

LOC		DIST		REVISIONS			
CM	00	P	LTN	DESCRIPTION	DATE	DWN	APVD
		L1		REVISED PER ECR-12-011660	04FEB2013	KH	TM

1. PARTS COMPLY TO AMP SOLDERABILITY SPECIFICATION 109-11-3.
2. CIRCUIT IDENTIFICATION CHARACTERS ARE ADJACENT TO THE INDICATED CAVITIES, BUT LOCATION AND ORIENTATION MAY DIFFER FROM PRINT.
3. DIMENSIONS IN BRACKETS ARE IN INCHES.
4. CONTACT IS STAMPED FROM PRE-PLATED STOCK WHICH IS PLATED OVERALL WITH 0.00127 [.000050] NICKEL; THEN STRIPED WITH 0.0076 [.000030] GOLD IN CONTACT AREA INDICATED AND MATTE TIN LEAD ON SOLDER TAIL END.
5. CONTACT IS STAMPED FROM PRE-PLATED STOCK WHICH IS PLATED OVERALL WITH 0.00127 [.000050] NICKEL; THEN STRIPED WITH 0.0076 [.000030] GOLD IN CONTACT AREA INDICATED AND MATTE TIN ON SOLDER TAIL END.
6. SUPERSEDED BY 643426-3

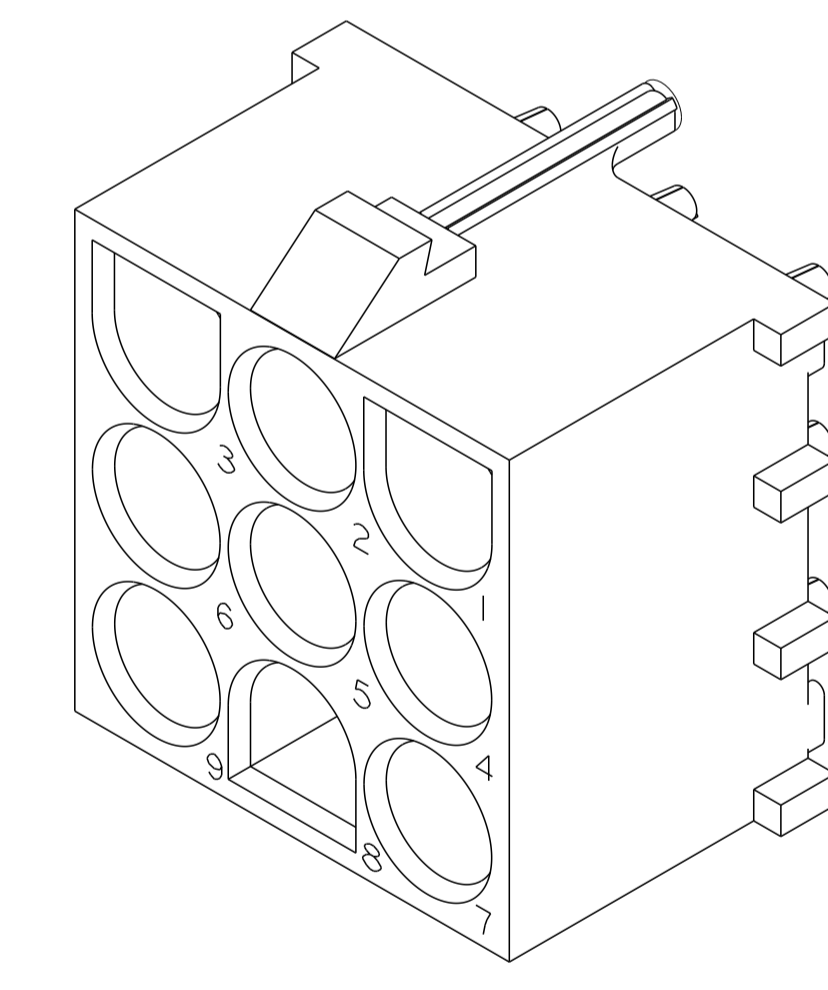

3 DIMENSIONAL MODEL  
SCALE 4:1

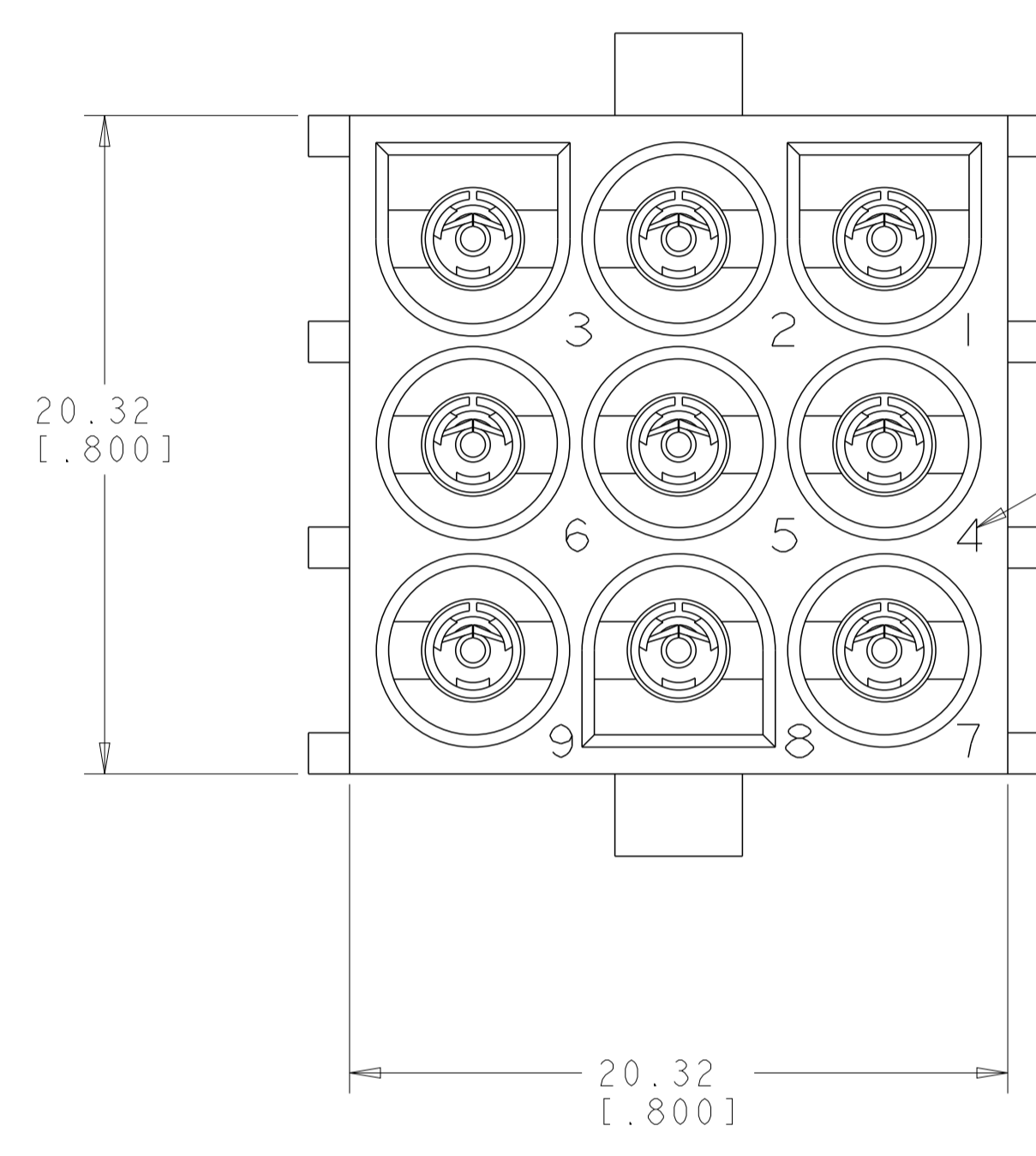
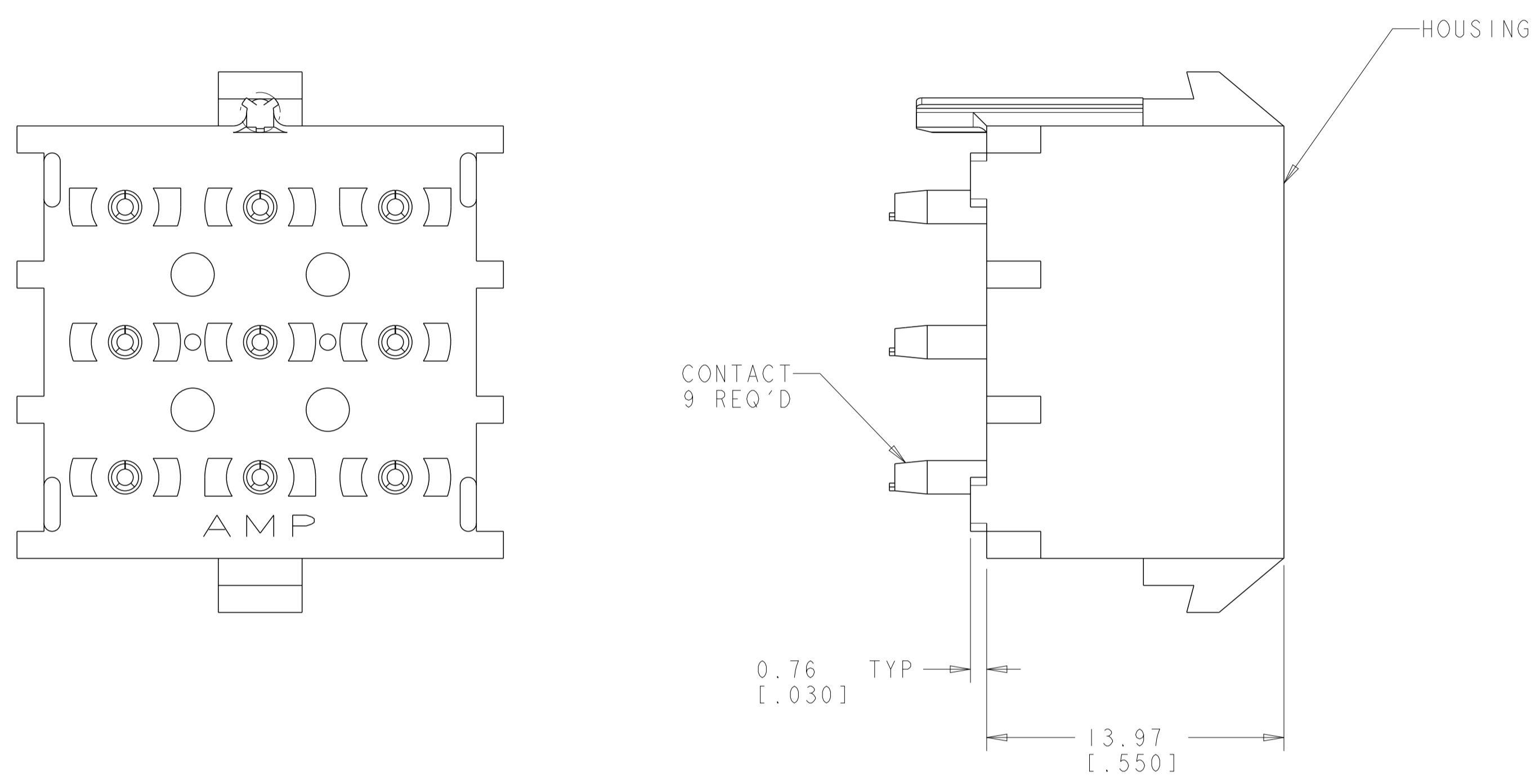
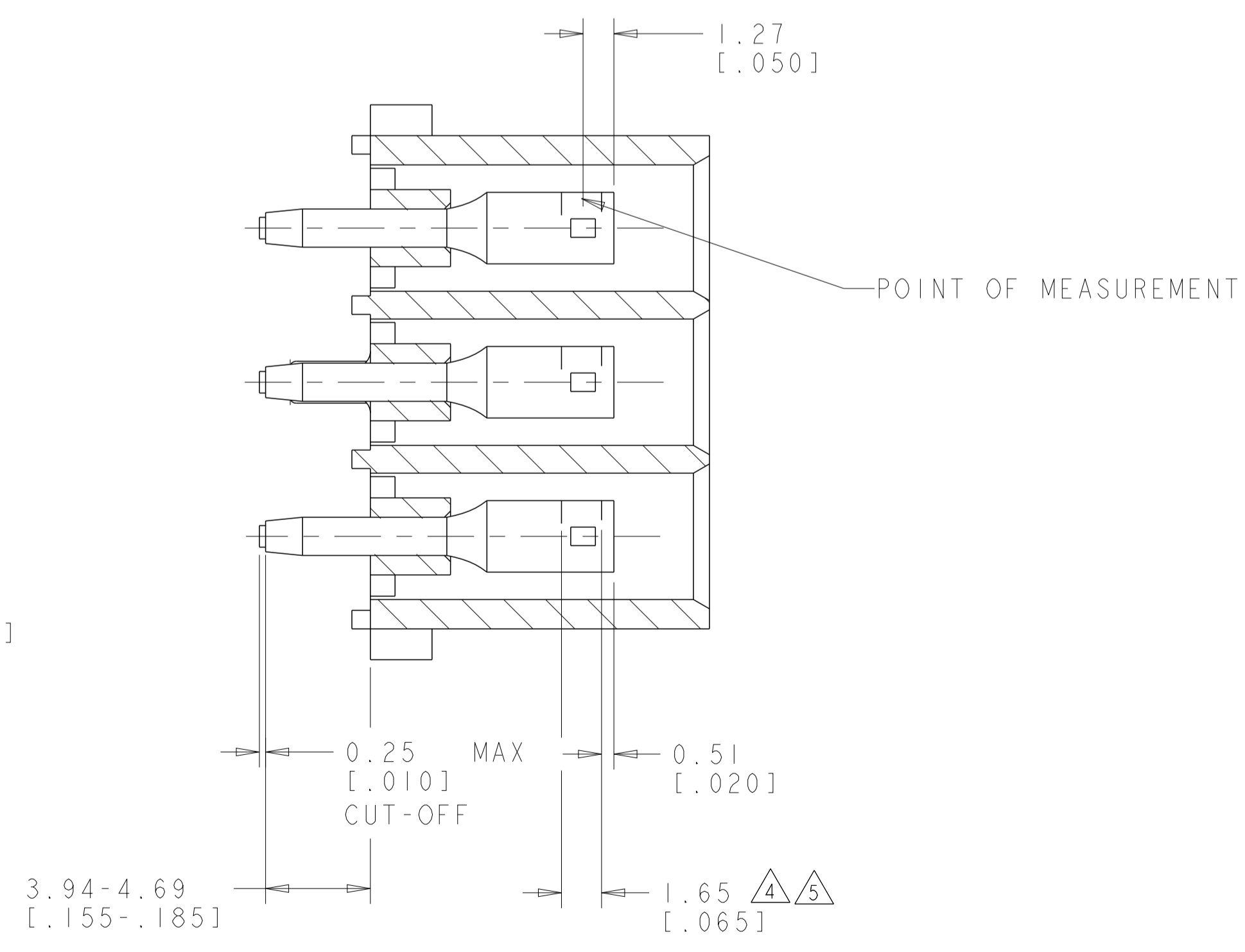
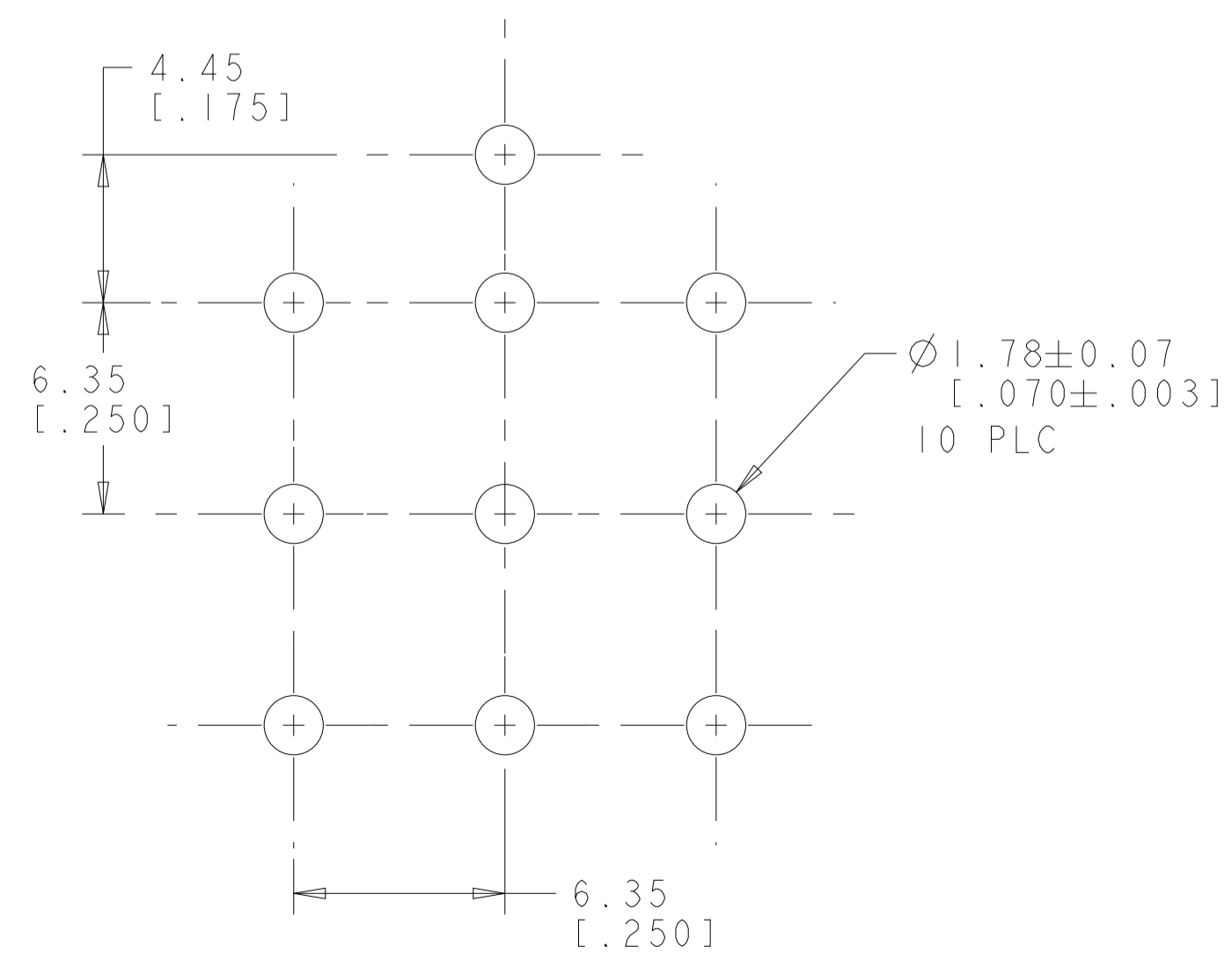

PIN CONTACT MATERIAL AND FINISH	HOUSING MATERIAL	PART NUMBER
PHOSPOR BRONZE, GOLD 5	NYLON, UL94V-0	643426-3
PHOSPOR BRONZE, GOLD 4	NYLON, UL94V-0	643426-2
PHOSPOR BRONZE, PRE-TIN	NYLON, UL94V-0	643426-1

RECOMMENDED MOUNTING HOLE PATTERN FOR 1.57 [.062] THICK P.C. BOARD

THIS DRAWING IS A CONTROLLED DOCUMENT.		DWN K. WHITAKER 29-JUL-2003	TE Connectivity	
DIMENSIONS: mm [INCHES]		CHK S. RIDGILL 29-JUL-2003	NAME HEADER ASSEMBLY, SOCKET, POLARIZED, 9 CIRCUIT, UNIVERSAL MATE-N-LOK™	
TOLERANCES UNLESS OTHERWISE SPECIFIED:		APVD S. RIDGILL 29-JUL-2003	PRODUCT SPEC	
0 PLC ±		APPLICATION SPEC		
1 PLC ±0.131(.005)		SIZE CAGE CODE DRAWING NO RESTRICTED TO		
2 PLC ±		A100779 643426		
3 PLC ±		WEIGHT		
4 PLC ±		CUSTOMER DRAWING		
ANGLES 40°/30°		SCALE 5:1 SHEET 1 OF 1 REV L1		
FINISH SEE TABLE				